

### Product Dimensions

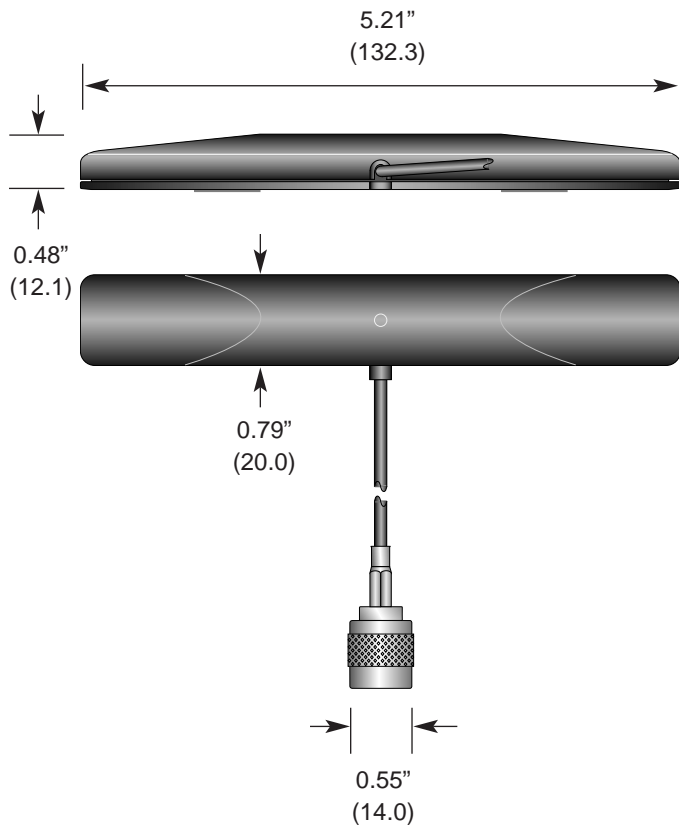

### Description



The HDP Series is a compact, center-fed antenna that achieves efficient operation at either or both of two frequency bands. Its durable, unobtrusive housing attaches permanently with integral adhesive to flat, non-conductive surfaces such as windows, drywall, ceiling tiles, plastic, etc. The antenna is supplied with 9.8 feet (3m) of RG-174 cable and can be terminated in an FCC Part 15 compliant RP-SMA connector or a TNC connector.

### Features

- Dual-band (860-960MHz and 1.77-1.88GHz)
- Compact & center-fed
- Surface-mount
- Low VSWR
- Excellent performance
- Omni-directional pattern
- Fully weatherized
- Durable & unobtrusive
- RP-SMA or TNC connector

### Electrical Specifications

- Freq. Bands. Band 1 860-960MHz  
Band 2 1.77-1.88GHz
- Bandwidth 200MHz
- Wavelength 1/2-wave
- VSWR <1.5 typ. at center
- Impedance 50 ohms
- Connector RP-SMA or TNC
- Cable 9.8' RG-174 coax

### Ordering Information

- ANT-DB1-HDP-RPS (with RP-SMA connector)
- ANT-DB1-HDP-TNC (with TNC connector)

### VSWR Graph

